

▲ SWITCH FUNCTION

POS. 1	POS. 2
ON	ON
1-3	1-2

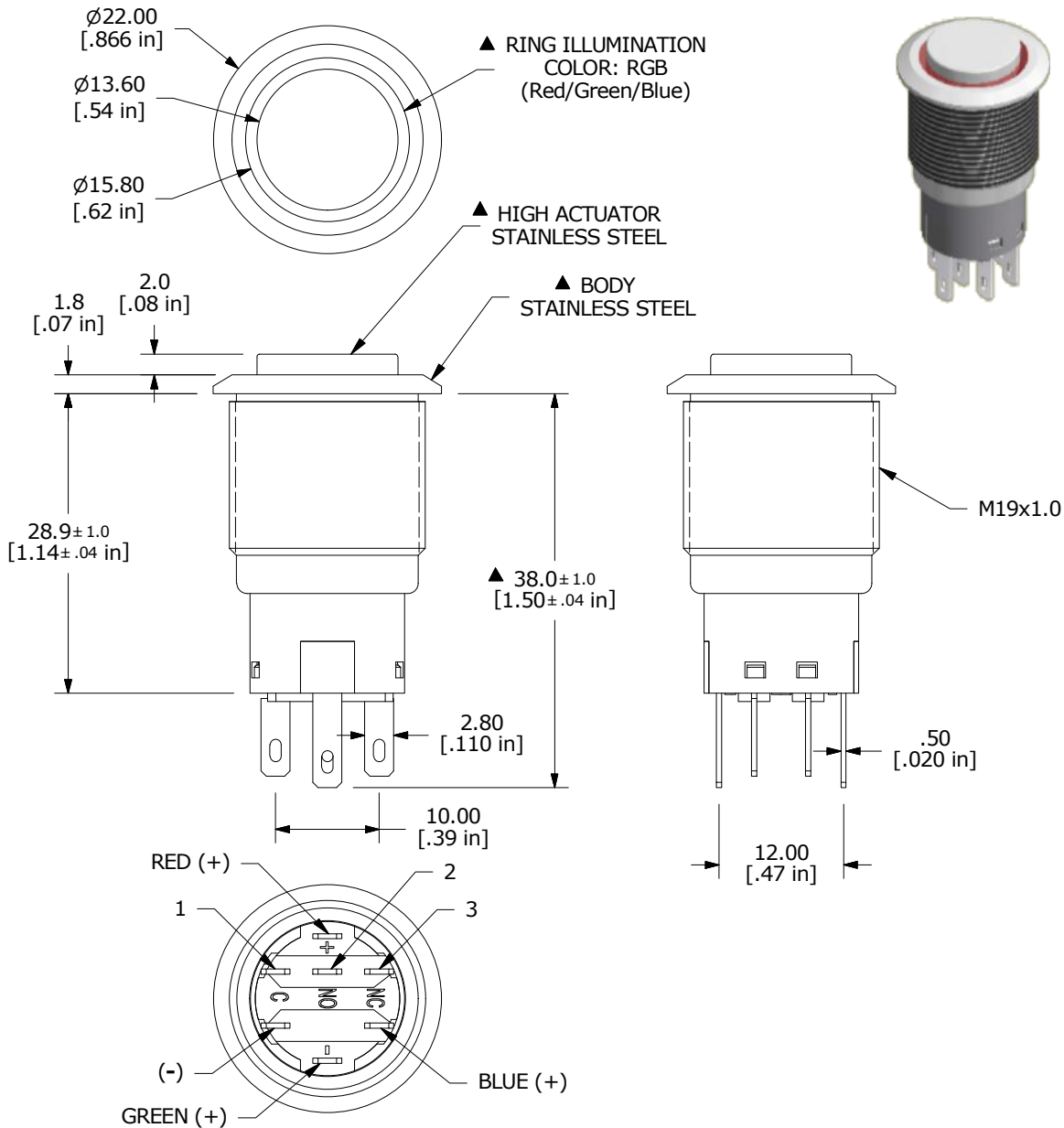

- NOTE:
- ALL DIMENSIONS IN mm [INCH]
 - GENERAL TOLERANCE: X.X = ±0.4
X.XX = ±0.25
 - TERMINAL NUMBERS FOR REF ONLY
 - CONTACT MATERIAL: GOLD
 - RATING: 2A 24VDC
 - ELECTRIC LIFE: 50,000 MAKE-AND-BREAK CYCLES AT FULL LOAD.
 - INSULATION RESISTANCE: 1,000 MΩ MIN.
 - DIELECTRIC STRENGTH: 2,000 VAC MIN. FOR 1 MINUTE
 - CONTACT RESISTANCE: 50mΩ MAX. @ 1A 12VDC
 - OPERATING TEMP.: -25°C to 55°C
 - TRAVEL: 2.8mm
 - ▲ DENOTES CRITICAL PARAMETER
 - INGRESS PROTECTION: IP67
 - HARDWARE SUPPLIED: O-RING AND HEXNUT
 - ILLUMINATION BASE RATING @ 20mA:
 RED- 1.8V
 GREEN - 2.8V
 BLUE - 2.8V

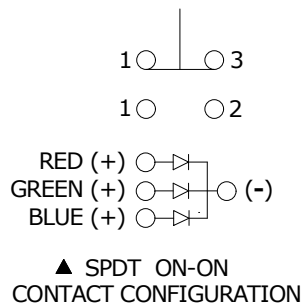

A	22860	New Release	5/23/17	MW
REV	PCR NO	DESCRIPTION	DATE	BY

THE INFORMATION CONTAINED IN THIS DOCUMENT IS PROPRIETARY TO E-SWITCH AND IS NOT TO BE COPIED OR TRANSFERRED

TITLE PV4H230SSG-3R1				
SCALE 3:2	DATE 5/23/2017	DR MW	DWG 52-PV4H230SSG3R1	REV A